

## Qwik-Point Installation Instructions:

1) Remove the 2 button head screws from the dew shield with a 1/8" Allen key. (You won't be needing the screws anymore.)

2) Attach the Qwik-Point adapter block using the socket-head cap screws and wrench supplied with the Qwik-Point (model QBT-1006).

3) Follow instructions packaged with Qwik-Point for alignment and use.

Since the Qwik-Point installs on the dew shield (sometimes called Sun Shade), it can be rotated to any convenient angle. It stores in the Tele Vue-60 carrybag with out need to remove it.



TV60OG 1003  
PRICE \$5.00  
Printed in U.S.A.

# OPERATING GUIDE Tele Vue-60



360mm f/6.0  
APO REFRACTOR

## OPERATING GUIDE

Congratulations on purchasing the Tele Vue-60 APO telescope. We worked hard to ensure that the Tele Vue-60 embodies all the performance and features of the finest astronomical-quality telescopes along with the compact size, ease-of-use, and versatility of a top spotting scope. Please take the time to read this operating guide to familiarize yourself with the various parts, operating suggestions and care instructions that will enable you to obtain maximum enjoyment from your new Tele Vue-60.



**WARNING:** NEVER look at the sun or point the telescope toward or near the sun without proper solar observing equipment rigidly secured in front of the objective lens. Instant and permanent eye damage will result from viewing the sun directly, even during a solar eclipse, or when viewing through thin clouds, or when the sun is near the horizon.

### 1. SET-UP SUMMARY

Follow these simple instructions to start using your Tele Vue-60 immediately. However, please read the complete operating guide including care instructions to get the most enjoyment out of your new Tele Vue-60.

#### 1.1 MOUNTING

*(Be sure to tighten the axes of your mount before attaching the Tele Vue-60.)*

A) Locate the three ¼-20 tapped holes in the bottom of the DOVETAIL BALANCE BAR. When using a photo tripod, choose any of the three threaded holes for attachment.

For the Tele Vue Tele-Pod or Panoramic Mounts, use the hardware included with the mount. Thread the ¼-20 studs into the two holes in the DOVETAIL BALANCE BAR that correspond with the clearance holes in the mounting's cradle and lock tightly. Place the telescope into the cradle so that the studs stick through the cradle's clearance holes. Lock the scope down with the wing nuts also supplied with the mount.

#### 1.2 SET-UP FOR VIEWING

A) Remove the plug from the end of the FINE FOCUS DRAW TUBE. Make sure the DIAGONAL LOCK SCREW is loosened enough so that the internal brass clamp ring is fully retracted. Insert an optional MIRROR DIAGONAL or ERECTING PRISM and tighten the DIAGONAL LOCK SCREW.

B) Place a low power eyepiece into the installed MIRROR DIAGONAL or ERECTING PRISM and tighten its lock screw.

Note: Mirror diagonals give upright images that are reversed left-right. Mirror diagonals are highly recommended to get the best optical performance from the Tele Vue-60. It is required for high power viewing and to obtain maximum image sharpness.

C) Squeeze the tabs on the LENS CAP to remove it.

## 11. SPECIFICATIONS:

Type	2-element APO refractor
Clear Aperture	2.4 inches (60mm)
Aperture Gain	73, compared to a 7mm eye pupil
Focal Length	14.2 inches (360mm)
Focal Ratio	f/6
Resolution (visual)	1.9 arc-sec. (Dawes Limit for a 2.4 inch aperture)
Resolution (photographic)	240 line pairs per mm
Magnification	11x to 180x using Tele Vue eyepieces
Close Focus	Approx. 10 ft.
Field Visual	4.3° at 11x (32 Pl), or 15x (24 Pan)
Field, 35mm film	3.8° by 5.7° (6.8° diagonal)
Image Scale	4.0° per inch
Focuser	1¼" draw tube, plus helical fine focus
Mounting	Adjustable balance bar with ¼-20 tapped holes for standard photographic tripods or optional Tele Vue mountings
Weight	approx. 3 lbs. (OTA only)
Length	10" (OTA only)
Tube	Black anodized aluminum
Accessories	Standard: Carry bag Optional: soft carrying case

Specifications subject to change without notice.

cleaning stroke use a fresh applicator. The fewer strokes the better! Any residual “film” will not effect visual performance.

The star diagonal has a first-surface mirror. It should be cleaned only when absolutely necessary. The Tele Vue 60° and 90° diagonal mirror should be removed for cleaning by removing the back cover's four screws, lifting the back off the diagonal body and cleaning the entire mirror surface. First blow loose dust away with a squeeze bulb. **CAUTION:** Do not clean mirror with water or water based cleaners such as Windex or any other commercial lens cleaners: this is not a lens. All contain too much water and will leave a residue. Use a Q-Tip moistened with pure acetone or methanol or Isopropyl alcohol (reagent grade). Wipe the surface gently. Use very light pressure and never rub. Slight residual stains or dust spots will have no visible effects in observing.

Clean either the Porro or 45° prism just like the mirror diagonal.

The black anodized surfaces of the Tele Vue-60 can be cleaned with “Windex.”

If you have any questions about the care, operation or performance of your Tele Vue-60, please call Tele Vue at (845) 469-4551 from 9:00 am to 5:00 pm EST.

## 9. A LAST WORD

The Tele Vue-60 was designed to adapt to your ever-changing interests, to be your personal “window to the world”. From the details of a bird across a lake, to the cloud bands of Jupiter, the rings of Saturn, or the craters of the moon, the Tele Vue-60 is always ready to thrill you with the wondrous sights of nature.

Remember to share your experiences with your family and friends. We would like to hear about your viewing experiences. Always feel free to call or write to us, especially if you have questions. We feel you are entitled to this level of support with the purchase of the Tele Vue-60. - And we hope you will feel as much pride in owning the Tele Vue-60 as we have had in building it for you.

We're proud the TV-60 was given the Smart Money Award for Best Overall Telescope. *Smart Money* magazine "wondered: What would the world's top amateur astronomer think" - of five scopes up to 10" aperture. Besides "giving the best view of Jupiter", this was David Levy's favorite scope because of its optics and ease of use.

## 10. WARRANTY

The Tele Vue-60 is warranted to be free of manufacturing or workmanship defects for 5 (five) years from the date of purchase. The telescope is individually factory aligned, and should not be taken apart for any reason. Any adjustment of the front lens cell will void your warranty. Do not tamper with it.

Returns require proper advance authorization.

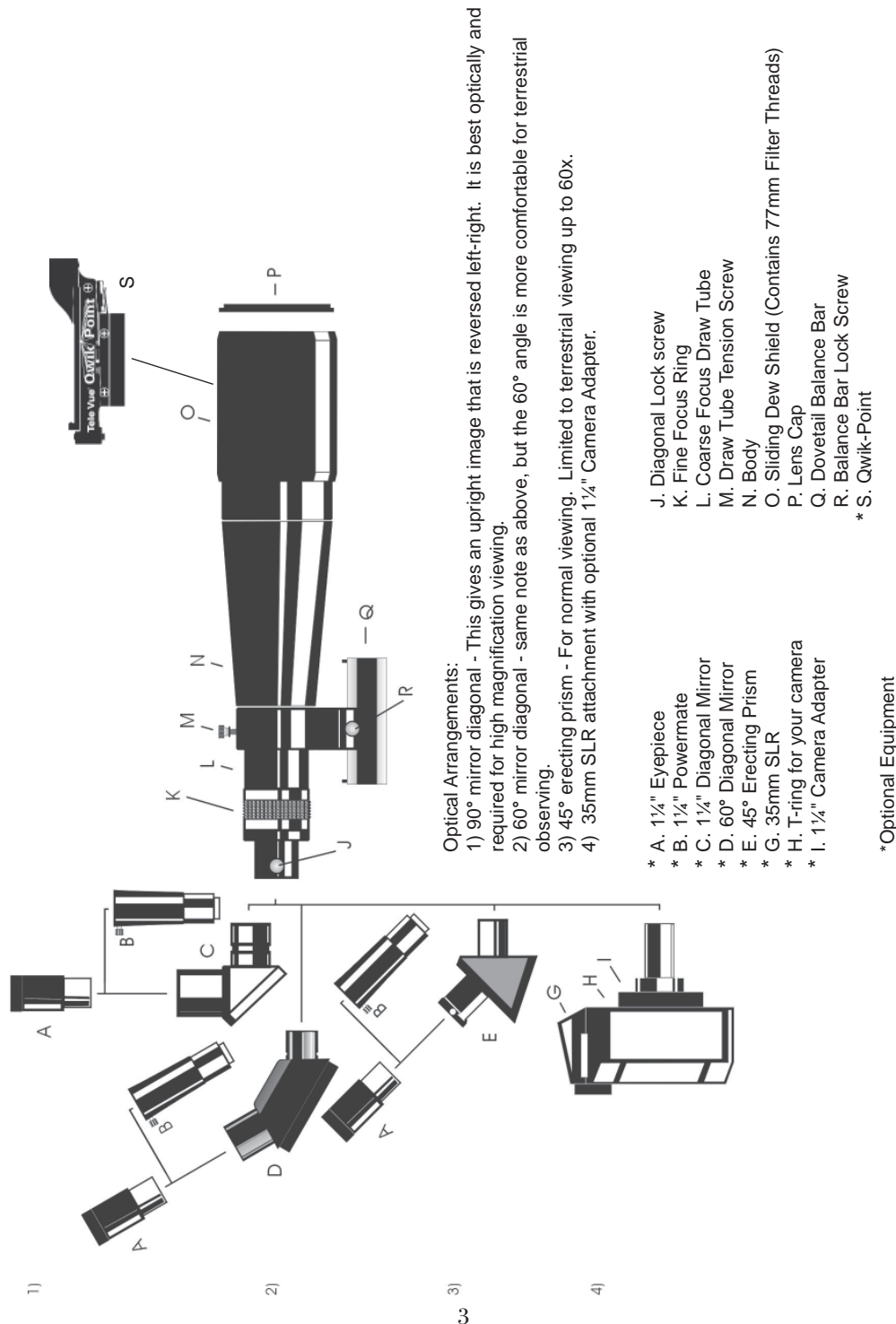

### 1.3 FOCUSING

A) Rotate the FINE FOCUS RING so it is set halfway through its travel. This will permit the greatest amount of +/- fine focus travel.

B) Point the scope towards an object you'd like to view.

C) Grasp the rubber grip ring on the FINE FOCUS RING and adjust the DRAW TUBE TENSION SCREW on top of the telescope body so that the push-pull action is loose enough to allow easy motion, but not so loose that the COARSE FOCUS DRAW TUBE slips backwards on its own.

D) Pull the COARSE FOCUS DRAW TUBE out until focus has roughly been achieved and lightly tighten the DRAW TUBE TENSION SCREW. **(CAUTION: DO NOT REPEATEDLY PUSH OR PULL THE DRAW TUBE QUICKLY. THIS PUMPING ACTION CAN DRAW DUST INTO THE TELESCOPE.)**

E) Now, rotate the FINE FOCUS RING until your object is in sharp focus.

### 1.4 BALANCE

The balance of the telescope may change depending on the eyepiece or camera used. To adjust the balance:

A) Loosen the BALANCE BAR LOCK SCREW.

B) Holding the TELESCOPE BODY, slide the entire telescope fore or aft until balance is reached.

C) Tighten the BALANCE BAR LOCK SCREW only enough to hold the scope in position. Do not overtighten.

## 2. TELESCOPE & SPOTTING SCOPE BASICS

Many people who use telescopes and spotting scopes are curious about just how they work. What is magnification power, and how does it work? It is very simple. When we wish to inspect a distant object more critically, we will intuitively bring it (or ourselves) closer. The “enlargement” from this closer proximity permits us to more easily see smaller details.

A telescope's *objective lens* forms an image of an object as if it were closer to the observer, like a telephoto camera lens. However, this real “image” is so small that, although enlarged, it is difficult to see any of its fine detail. Therefore, a “magnifier,” called an *eyepiece*, is used to look at a portion of the “image” in greater detail. The magnification, therefore, depends on the relationship between the focal lengths of the objective (to form the image) and the eyepiece (to enlarge the image). To figure out the magnification factor, divide the telescope's focal length by the eyepiece focal length. For example, the Tele Vue-60's 360mm objective used with an 20mm eyepiece yields 18 power. ( $360 \div 20 = 18x$ )

The combined qualities of the objective lens and the eyepiece (as well as anything else in the light path between them, such as prisms or mirrors—see below) help determine the quality of the magnified view. One of the secrets of the Tele Vue-60's extraordinary optical performance is its partnership with the family of Tele Vue eyepieces.

For terrestrial use, *prisms* are often employed to provide a correct presentation of the objective's image, as well as folding the light path to make the instrument more compact and/or easier to use. In most terrestrial spotting scopes, the prisms are built in, and are not removable. Most astronomical telescopes have no prisms, since the image erecting

60 as you would normally.

With the Tele Vue-60 on your camera, you have a 360mm, f/6 telephoto lens! This is about 7x the magnification of a 50mm lens. The Tele Vue-60's fast f/6 performance is great with DSLR's with APS format, ideal for high resolution nature photography.

B) AFOCAL PHOTOGRAPHY — Tele Vue's afocal camera adapters permit your digital camera to zoom into your image! Adapters are available for digital cameras with 28mm, 37mm and 49mm filter threads. If your camera lens (or lens cover tube) has a different thread, you can usually find a step-up or step-down ring to mate with one of the Tele Vue thread sizes of 28/37/49mm. Best results occur with long eye-relief eyepieces such as 32mm Plössl.

## 7. ACCESSORIES

A) CARRY BAG — The Tele Vue-60 is supplied standard with a GORE-TEX® bag which has been sized to fit the Tele Vue-60 optical tube plus diagonal and eyepiece. Always pull the draw string taut and slide the string lock down against the bag when the scope is in place.

B) SOFT CARRY CASE — The optional carry case measures just 13" long x 9" wide x 4" deep, and holds the Tele Vue-60 optical tube, diagonal or prism of your choice, plus three eyepieces in custom die-cut foam. The Nylon soft case is padded and comes with both a carry handle and shoulder strap.



**When packing up for the evening, always install the front lens cover and close Tele Vue-60 in the optional carry case or its bag box before bringing the telescope inside. Do not open the bag or box until it reaches room temperature. This will prevent dew from forming on the telescope. If excessive dew builds up on the telescope body, wipe it off with a soft cloth.**

## 8. CARING FOR THE TELE VUE-60

The Tele Vue-60 requires no special care. Treat it as you would any fine camera lens. Use the lens cap when the telescope is not in use or being stored.

As stated earlier, do not pump the draw tube in and out quickly. This can cause dust or airborne grit to be drawn into the telescope.

If you leave your scope idle in dewy conditions it is always a good idea to tilt the telescope slightly up. If dew forms on the lens during cold weather, it is best to use an electric hair dryer (on the lowest setting) to gently warm it away. A few specks of dust will have no effect on the quality of the image, and may be gently blown off with a squeeze bulb. Do not use compressed air cans to blow dust off any optical surfaces.

Fingerprints, however should be cleaned off. Though the anti-reflection coatings are durable, they can be scratched. The simplest cleaning method is to moisten a very soft, lint-free tissue, cloth, “Q-Tip” or surgical cotton with a lens or glass cleaner and gently whisk away the stain. Do not apply any solutions directly to the glass surfaces. After every



**Put a red filter over your flashlight to prevent disturbing your eyes' dark adaptation.**

**Objects are best observed when they are as high overhead as possible. By looking through less air, the amount of atmospheric turbulence and dimming (caused by absorption) is considerably reduced.**

a television picture, where the closer you get to the tube, the more detail you can see, until you get so close that you see the screen's dot pattern. Once the dot pattern is observed, no additional detail can be seen by moving closer to the set. The same principle applies to telescope magnification and resolution. When the resolution limit is reached (at higher magnifications and with steady air), stars will appear as small discs with one or more surrounding faint rings of light.

Experiment with viewing double stars or lunar detail, and you will quickly discover those magnifications which are best suited to the object, your eyes, and the steadiness (seeing conditions) of the Earth's atmosphere. Cold, crisp winter nights offer excellent transparency for seeing faint and elusive deep-sky objects, but the accompanying air currents (turbulence) often will make the moon or planets appear as if they are viewed under moving water. This is the reason that bright stars twinkle so noticeably on these nights. On the other hand,



**Faint objects can be more readily detected by using a technique called "averted vision". Try looking slightly away from the faint object you would like to observe and you will notice that it appears to get brighter. This is due to the position of the more light sensitive rods lining the outer area of the retina. Experiment with the direction in which you avert your vision since a particular area of your eye might be more sensitive than another.**

hazy summer nights with still, "dead" air (poor transparency but good "seeing") are often ideal for observing fine lunar detail, spotting planetary features, and separating close double stars at the highest magnifications.

You will also enjoy views of the Ring Nebula (M57) and the Dumbbell Nebula (M27). Close double stars such as Epsilon Lyrae (the "Double-Double") can be split at high magnifications. Check [www.televue.com](http://www.televue.com) for more technical articles.

## 6. THE TELE VUE-60 AND PHOTOGRAPHY

### 6.1 PHOTOGRAPHIC METHODS USING THE TELE VUE-60

The Tele Vue-60 can be used with 35mm single lens reflex (SLR) cameras or as an afocal system with an eyepiece and digital camera.

A) PRIME FOCUS 360mm TELEPHOTO — For 35mm cameras, remove either the diagonal or erecting prism and install the optional 1¼" camera adapter (ACM-1250). A "T"-ring to mate your particular brand of camera to the adapter can be obtained at any camera store. With camera mounted, look through the viewfinder and focus the Tele Vue-

function is unnecessary for viewing the sky. However, *mirror* diagonals are used to provide easier viewing postures for the observer. Your Tele Vue-60 telescope can be used with either prisms or mirror diagonals, providing maximum versatility for either use. Since prisms and mirrors are in the "light path," they must be of very high quality, or they will degrade the overall performance of the objective and eyepiece. (*All Tele Vue prisms and mirror diagonals are individually inspected and tested to ensure the highest quality possible.*)

In order for a telescope to be properly and clearly in focus, the eyepiece must be at the precise distance from the objective lens. This distance may vary with the type of eyepiece as well as the distance to the object being viewed. For terrestrial viewing, where the object distance can vary greatly, there ideally should be both gross and fine adjustments in order to handle all focussing situations quickly and easily. The Tele Vue-60 can focus from approximately 10 feet to infinity.

Another factor affecting the focus "position" is the corrective error of the observer's eye (i.e. if you require eyeglasses), and whether you are wearing them or not. These variables are accommodated by the *focuser*, which provides the mechanical adjustment for a range of focus positions.

That's all there is to the basic operation of a telescope or spotting scope.

## 3. GETTING ACQUAINTED WITH THE TELE VUE-60

The more you know about each part of the Tele Vue-60, the quicker you will become familiar with its use and many capabilities.

### 3.1 OPTICAL TUBE ASSEMBLY

The optical tube assembly is the heart of the telescope. It consists of the front lens cell with captive dew shield, snap-on lens cover, anodized aluminum body, and focuser. The Tele Vue-60 is an air-spaced doublet apochromatic design using the finest quality special dispersion glasses. The objective produces diffraction limited resolution with color correction far exceeding that of a "classic" f/15 achromat.

The two lens elements contained in the optical tube assembly are critically aligned to deliver all the sharpness inherent in this unique design. Never loosen the lock screws in the lens cell as this will affect collimation and void the warranty.

The end of the dew shield is threaded to accept 77mm photographic filters. A filter is recommended to protect the objective lens when observing in shore environments. Care must be taken to select the highest optical quality filter possible so as not to affect the image quality. It is recommended to always remove any aperture filter for astronomical observing.

### 3.2 1¼" FOCUSER

Tele Vue-60's 1¼" dual-action draw tube/helical type focuser is individually hand fitted to obtain a smooth and accurate focus action. A tension/lock screw is located on top of the focuser body. It can be used to add resistance against the focuser's draw tube. This is especially valuable when using heavy eyepieces and cameras.

### 3.3 ERECTING PRISMS AND MIRROR DIAGONALS (OPTIONAL)

A) 45° ERECTING PRISM — The viewing angle allows comfortable terrestrial and astronomical observing and is best used at low and medium powers, up to approximately 60x.

B) 60° DIAGONAL — The Everbrite dielectric coated mirror takes full advantage of the performance capability of the Tele Vue-60 with a comfortable viewing angle for terrestrial observing. The image orientation is correct top-to-bottom, but left-right reversed.

C) The 90° 1¼" Star Diagonal can be supplied with either a 96% reflective enhanced aluminum mirror coating or 99% reflective Everbrite coating. The Everbrite's optical advantage in neutral coloration and scatter control is seen under critical evaluation at high power on the Moon and major planets. It is a durable, non-metallic coating which will maintain its reflectivity over time.

Diagonals offer higher optical performance than prism units, most effectively noticed at powers above 80x. The image is right side up, but reversed left-right.

All of the above items are available individually, and are interchangeable on the Tele Vue-60.

### 3.4 EYEPIECES (OPTIONAL)

As previously discussed, the function of the eyepiece is to magnify the image formed by the objective. Choosing eyepieces involves making decisions based on object type, physical constraints and personal preferences. The Tele Vue-60 accepts only 1¼" barrel eyepieces. Consult the magnification table in this operating guide for eyepiece/Powermate magnifications. For more detailed information on eyepiece specifications when used with the Tele Vue-60, try our eyepiece calculator at [www.televue.com](http://www.televue.com), or call us for recommendations.

### 3.5 MOUNTING/BALANCE BAR

The captive dovetail mounting/balance bar, referred to simply as the balance bar, allows the Tele Vue-60 to be attached to a number of tripod or mount types, including camera/video, alt/azimuth or equatorial. It also slips into the Tele Vue SCT Bracket (SBB-1002) making the Tele Vue-60 the ultimate finder/Rich-Field accessory for your SCT! The thick aluminum bar provides a solid footprint and resists vibration. A thumb screw locks the balance position, while providing easy adjustment when necessary.



Dovetail Balance Bar — end holes for Tele Vue mounts, middle holes for camera/video tripods. Holes 1, 3 & 4 have ¼-20 threads. Hole 2 is for the anti-rotation pin found on camera/video tripods.



**To easily follow a moving object when viewing with a mirror diagonal, just remember to push the back of the telescope in the same direction that the object appears to be moving in the telescope. For example, if a bird is flying through the field from left to right, swing the back of the scope from left to right.**

of stars, and galaxies will appear different from the photographs and illustrations in books and magazines. Long duration photos made at major observatories present views of objects which cannot be duplicated visually by telescopes of *any* size.

However, the visual observer can perceive contrasts and ranges of brightness that are impossible to duplicate in any photograph. Ask anyone who has observed the delicate swirls of the Orion nebula, or better yet, try it out yourself when this nebula is above the horizon. You can see the jewel-like Trapezium stars at the center of the nebula simultaneously with the petal-like “arms” of nebulosity that seem to curve up and over the brighter central regions of gas. Photos in books can show one or the other, but rarely both! The Tele Vue-60's unique design provides high contrast and sharpness over a very wide magnification range.

A) LOW POWER VIEWING - Magnifications at the lowest end of the Tele Vue-60's range provide wide, extremely sharp fields - ideal for finding your target, for wide angle sweeps of the Milky Way, and for beautiful views of large open clusters such as the Pleiades (M45), the Beehive (M44), and the Double Cluster in Perseus. (NGC-869 and NGC-884).

Low power viewing is also the best way to see the Andromeda Galaxy (M31). In autumn and winter, the rich star clusters in Cassiopeia and Auriga are beautiful.



**To reach critical focus, go through each side of focus a few times. Each time, de-focus less and less. Focus position is critical to both sharpness and best color correction.**

The nightly motion of our moon occasionally causes it to pass through or near rich star fields. A crescent moon floating among the bright jewels of the Pleiades is a sight not soon forgotten. We encourage you to share such beautiful and special celestial events with your friends and family.

B) MEDIUM AND HIGH POWER VIEWING - Using eyepieces of shorter focal length increases the magnification of the Tele Vue-60, and lets you direct your attention to even finer lunar and planetary detail, and to the myriad of double and multiple star systems. Many observers are delighted and surprised with the superior detail seen in high-power views of some nebulae. These extended objects often have low brightness levels and contrast poorly against brightly-lit urban and suburban sky backgrounds. By increasing your telescope's magnification, the sky background darkens, fainter stars are visible and the enlarged subject becomes much more striking.

Optical theory tells us that with ideal eyesight you can see all of Tele Vue-60's resolution at just 40 power. In practice though, most people require magnification about 2 to 3 times more (80x to 120x) to view all the resolution comfortably. Much like looking at



When changing eyepieces, always have the eyepiece you are changing to in hand and ready to install. This will minimize the chances for dust or dirt to settle on your diagonal mirror.

### 5.3 TERRESTRIAL OBSERVING

For terrestrial observing we suggest using a high quality multi-coated, 77mm UV haze filter which screws into the front dew shield. This also helps protect the lens. (You should remove the filter for the sharpest possible high power astronomical viewing.) Terrestrial observing generally takes advantage of the Tele Vue-60's low and medium powers. Low magnifications yield wide fields-of-view which help you to find object easily.

The upper ends of the medium power magnifications reduce your field of view and are recommended when subject brightness allows. Also, these higher magnifications often increase the blurring-effect of air currents, wind, and vibrations. To maximize viewing comfort, avoid using over 70x when viewing over asphalt paving or any warm surface, or through an open window. In these cases, magnification of air currents by the telescope will significantly degrade image steadiness and sharpness. Image sharpness may also be reduced when viewing through window glass.

In any case, you will marvel at the clarity of your "window to the world," whether as a long distance microscope, a spotter for bird watching, or for viewing over water scenes.

### 5.4 ASTRONOMICAL VIEWING

The Tele Vue-60's "diffraction limited" design coupled with its aperture, focal length, and overall physical size make it a truly portable instrument. It's easily set up, and with its optional custom fitted soft case, it is rugged enough for travel by land, sea or air. Why not take it along to your favorite distant and exotic viewing sites?

Astronomical viewing presents challenges different from those of terrestrial viewing. With the exception of the moon, planets, and brighter stars, your viewing targets are not necessarily visible to your naked eye. Remember that views of nebulae, clusters



**For correcting near- or farsightedness, there is generally no need to wear your glasses, since focusing the telescope will compensate for your eyesight.**

**If, however, if you suffer from eyesight astigmatism you will either need to use your glasses or a Tele Vue Dioptrx to get the sharpest view. Dioptrx has some advantages over standard eyewear. First, it's made of the highest quality optical glass and is multicoated, just like the lenses in your Tele Vue eyepieces. Dioptrx is fully rotatable (tunable) to exactly match the axis of your astigmatism. Finally, you will always be looking through the center of the Dioptrx lens for optimal correction. Learn more about Dioptrx at [TeleVue.com](http://TeleVue.com).**

## 4. MOUNTING THE TELE VUE-60

To use magnifications higher than about 10x, you need to stabilize the telescope by mounting it on a tripod. A quality photo tripod or any in our complete line of mounts can be used. Several standard ¼-20 tapped holes are provided to accommodate all types of tripods. If you should change eyepiece sizes or weights, or should mount a camera, you may have to reposition the Tele Vue-60 for best balance. This will reduce the amount of observable vibration, or tremors seen at higher magnifying powers, and gives you the smoothest mount movement.

For mounting the Tele Vue-60 on any Tele Vue tripod, follow the instructions supplied with each unit. All necessary hardware is included with the tripod.

In general, the heavier the tripod, the more stable and effective it is at high magnification (100x to 150x). For specific mounting instructions, refer to the documentation provided with your mount.

### 4.1 TELE VUE MOUNTING OPTIONS

A) TELE-POD HEAD — Mounting the Tele Vue-60 on a tripod with a standard camera head is fine for terrestrial viewing. However, problems arise when tilting up from the horizon. The weight of the telescope will always be fighting gravity.

The yoke and cradle design of the Tele-Pod Head solves this problem by moving the altitude pivot axis near to the center of gravity of the telescope. In this balanced state the telescope will stay where it's pointed. The Sky Tour digital setting circle system and Eyepiece Caddy Set are great bolt-on accessories.

The Tele-Pod head simply threads onto either the center post of your camera tripod (no need for the camera head) or onto the camera head itself.

B) TELE-POD MOUNT — Weighing 7 lbs. the Tele-Pod mount combines the Tele-Pod head with a light weight camera tripod. It is the ideal mount for the Tele Vue-60 with the added ability to use the Sky Tour and Eyepiece Caddy Set.

C) PANORAMIC MOUNT — The Panoramic Mount puts the Tele-Pod head atop a beautiful ash or walnut tripod. A convenient accessory tray is included.

### 4.2 CAMERA TRIPOD MOUNTING

The standard ¼-20 tapped holes in the mounting bar allows the Tele Vue-60 to be mounted on any heavy duty camera tripod.

### 4.3 ADAPTERS FOR EQUATORIAL MOUNTING

A) Tele Vue offers an adapter plate (Part# AVT-1011) that allows the Tele Vue-60 to be mounted on Great Polaris or Sphinx equatorial mounts from Vixen.



**Never underestimate the value of comfort in observing. Use the star diagonal to avoid "craning" your neck for astronomical observing. An adjustable height observer's stool such as Tele Vue's Air-Chair is a great way to keep from getting tired.**



An easy way to center bright objects is to remove the eyepiece and look down into the diagonal from a foot away. Place the bright object (moon, planet etc.) as close to center as possible. Reinstall a low power eyepiece and further center the object.

## 5. OBSERVING WITH THE TELE VUE-60

### 5.1 HOW TO POINT THE TELE VUE-60

A) LOW POWER EYEPIECE — By inserting low power eyepieces, the Tele Vue-60 can be used as its own finder for locating objects to be observed at higher magnifications. For the widest field possible, you should use either the Tele Vue 32mm Plössl or the 24mm Panoptic which provides viewing at 11x or 15x respectively with a whopping 4.3° true field (over 8 full moon diameters).

B) QWIK-POINT — This accessory projects a "red dot" where the telescope is pointed and attaches to the telescope's dew shield. (See back page for instructions.)

### 5.2 EYEPIECE RECOMMENDATIONS

The optical performance of your Tele Vue-60 telescope is based on its high quality objective lens. However, every other item in the telescope's light path will affect the final image quality. To obtain the highest performance from your Tele Vue-60 telescope, you should select only eyepieces, prism or mirror diagonal assemblies by Tele Vue Optics .

Although the variety of eyepieces seems daunting, you only need a few to cover a broad magnification range. Choose the best eyepieces you can afford, rather than the most. Many factors are involved in choosing the right eyepiece for you. Please call us for advice. Below are our suggestions for getting started with your Tele Vue-60.

Starting with low power, the 24mm Panoptic at 15x provides the largest true field, 4.3°. For medium power, a 9mm Nagler Type 6 delivers 40x, great for terrestrial as well as rich-field deep sky observing. The 8mm Ethos would be a great alternative to the 9mm Nagler. At high power your subject will appear to move through the field quickly. Therefore, if the eyepiece focal lengths were the same, an 82° Nagler eyepiece would permit longer observing times before having to move the telescope. In practice, the true field differences for our high power recommendations are small because the magnifications are different. For high power, choosing either a 2.5mm Nagler Type 6 (144x), or 3-6mm Zoom (60x-120x) will give you a minimum of two minutes time to view an object on the meridian (worst case) before having to reposition the telescope.

Although Ethos eyepieces are larger, heavier and more costly, the 100° apparent field of view gives a unique "wow" experience. Ethos 13mm, 10mm, 8mm, 6mm and 4.7mm, 3.7mm (with 110°) all work with the TV-60. The Delos line with its 20mm of eye relief is excellent day or night for eyeglass wearers. Available focal lengths 17.3mm, 14mm, 12mm, 10mm, 8mm, 6mm, 4.5mm and 3.5mm.

Though the Tele Vue-60 is capable of significantly higher powers, the number of subjects bright enough for such magnifications are limited to the Moon, major planets and some double stars. Please note going to higher powers than recommended produces a larger image, but no resolution gain. Atmospheric turbulence will also often limit the amount of magnification that can be used.

Tele Vue-60											
Focal Length (mm)	Type	Product Code	Apparent Field(deg)	Field Stop Dia. (mm)	Eye Relief (mm)	Weight (lb.)	Mag.	True Field (deg)	Exit Pupil (mm)	# of Elem.	Dioptrx Ready
<b>1¼" Eyepieces for Wide True Fields</b>											
40	Plössl	EPL-40.0	43	27.0	28	0.4	9.0	4.30	6.7	4	Y
32	Plössl	EPL-32.0	50	27.0	22	0.4	11.3	4.30	5.3	4	Y
24	Panoptic	EPO-24.0	68	27.0	15	0.5	15.0	4.30	4.0	6	Y*
13	Ethos	ETH-13.0	100	22.3	15	1.3	27.7	3.55	2.2	-	Y
16	Nagler 5	EN5-16.0	82	22.1	10	0.4	22.5	3.52	2.7	6	N
19	Panoptic	EPO-19.0	68	21.3	13	0.4	18.9	3.39	3.2	6	Y*
25	Plössl	EAP-25.0	50	21.2	17	0.3	14.4	3.37	4.2	4	N
17.3	Delos	EDL-17.3	72	21.2	20	0.9	20.8	3.37	2.9	-	Y
18.2	Delite	EDE-18.2	62	19.1	20	0.5	19.8	3.04	3.0	-	Y
10	Ethos	ETH-10.0	100	17.7	15	1.1	36.0	2.82	1.7	-	Y
13	Nagler 6	EN6-13.0	82	17.6	12	0.4	27.7	2.80	2.2	7	Y*
14	Delos	EDL-14.0	72	17.3	20	0.9	25.7	2.75	2.3	-	Y
20	Plössl	EAP-20.0	50	17.1	14	0.2	18.0	2.72	3.3	4	N
12	Nagler 4	EN4-12.0	82	17.1	17	1.0	30.0	2.72	2.0	6	Y
15	Delite	EDE-15.0	62	16.0	20	0.5	24.0	2.55	2.5	-	Y
<b>1¼" Eyepieces for Medium Powers</b>											
12	Delos	EDL-12.0	72	15.0	20	0.9	30.0	2.39	2.0	-	Y
11	Nagler 6	EN6-11.0	82	14.9	12	0.4	32.7	2.37	1.8	7	Y*
13	Delite	EDE-13.0	62	13.8	20	0.5	27.7	2.20	2.2	-	Y
10	Delos	EDL-10.0	72	12.7	20	0.9	36.0	2.02	1.7	-	Y
15	Plössl	EAP-15.0	50	12.6	10	0.2	24.0	2.01	2.5	4	N
9	Nagler 6	EN6-09.0	82	12.4	12	0.4	40.0	1.97	1.5	7	Y*
11	Delite	EDE-11.0	62	11.7	20	0.4	32.7	1.86	1.8	-	Y
9	Delite	EDE-09.0	62	9.6	20	0.5	40.0	1.53	1.5	-	Y
11	Plössl	EAP-11.0	50	9.1	8	0.1	32.7	1.45	1.8	4	N
<b>1¼" Eyepieces for Higher Powers</b>											
8	Ethos	ETH-08.0	100	13.9	15	1.0	45.0	2.21	1.3	-	Y
6	Ethos	ETH-06.0	100	10.4	15	1.0	60.0	1.66	1.0	-	Y
8	Delos	EDL-08.0	72	9.9	20	1.0	45.0	1.58	1.3	-	Y
7	Nagler 6	EN6-07.0	82	9.7	12	0.5	51.4	1.54	1.2	7	Y*
4.7	Ethos SX	ETH-04.7	110	8.9	15	1.3	76.6	1.42	0.8	-	Y
6	Delos	EDL-06.0	72	7.6	20	1.0	60.0	1.21	1.0	-	Y
7	Delite	EDE-07.0	62	7.5	20	0.5	51.4	1.19	1.2	-	Y
3.7	Ethos SX	ETH-03.7	110	7.0	15	1.1	97.3	1.12	0.6	-	Y
5	Nagler 6	EN6-05.0	82	7.0	12	0.5	72.0	1.11	0.8	7	Y*
8	Plössl	EAP-08.0	50	6.5	6	0.1	45.0	1.03	1.3	4	N
4.5	Delos	EDL-04.5	72	5.6	20	1.1	80.0	0.89	0.8	-	Y
5	Delite	EDE-05.0	62	5.3	20	0.5	72.0	0.84	0.8	-	Y
3.5	Nagler 6	EN6-03.5	82	4.8	12	0.5	102.9	0.76	0.6	7	Y*
3.5	Delos	EDL-03.5	72	4.4	20	1.1	102.9	0.70	0.6	-	Y
4	Delite	EDE-04.0	62	4.3	20	0.5	90.0	0.68	0.7	-	Y
2.5	Nagler 6	EN6-02.5	82	3.4	12	0.5	144.0	0.54	0.4	7	Y*
3	Delite	EDE-03.0	62	3.2	20	0.5	120.0	0.51	0.5	-	Y
<b>1¼" Zoom Eyepieces for Medium and Higher Powers</b>											
6-3	Nagler Zoom	ENZ-0306	50	5.1-2.6	10	0.3	60.0-120.0	0.81-0.41	1.0-0.5	5	N

†12mm Nagler T4 not recommended for daytime use. \*Additional Dioptrx Adapter required